

910021NT

Thermostatic Mixing Valve

Feature:

Structure is simple and reliable

Thermostatic protection

High flow rate

Adjustable outlet temperature

High flow rate

Adjustable outlet temperature

Temperature steady-going

Ease use and installation



Technical parameter:

Material: Brass+ABS

Max pressure(static): 16 bar

Max working pressure: 5 bar

Max inlet temperature: 90°C

Adjustable temperature range: 30-65°C

KV: 3.0 m³/h

Flow rate: 60L/min

Temperature Stability: $\pm 2^{\circ}\text{C}$

Application:

Living Water、 Under Floor Heating、
Solar Water Heater、 Electric Water Heater

Sanitary

Heating and cooling system

Customize Solution:

If you are not sure about the parameters of thermostatic mixing valve, our engineering team will assist you with your selection or customize according to these details as follow:

Mixing water temperature range

Pressure and loss of pressure

Performance standard

Custom material and other parts

Dimensione:

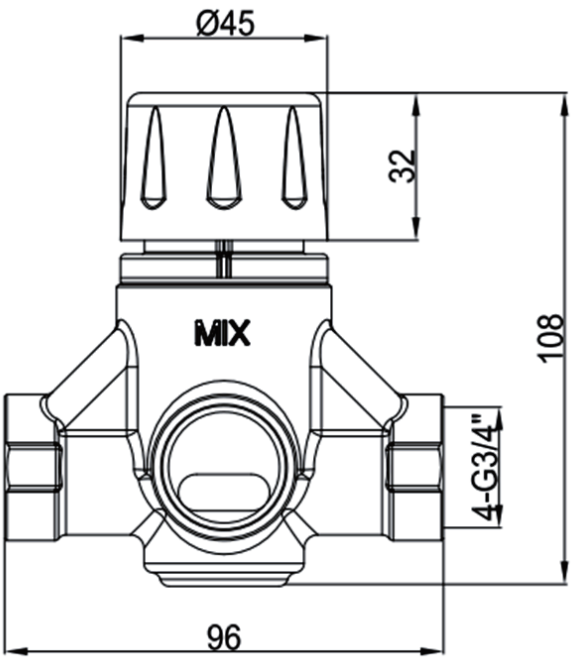
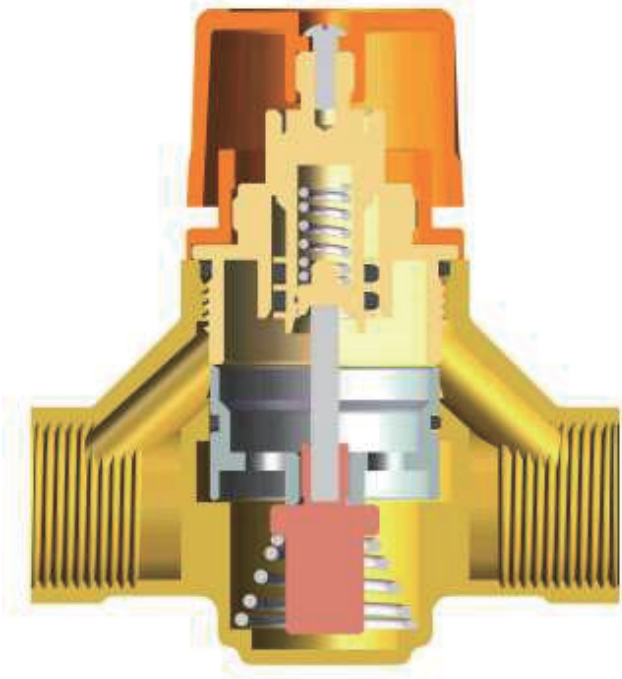

Flowing Curve:

