

910033NT Water Return System Control Valve



Technical parameter:

Material: Brass

Proof Pressure: 10 Bar

Close Temperature Range: 35-37°C

Open Temperature Range: 30-33°C

Mixing water temperature range: 55°C -75°C

Application:

Sanitary

Heating and cooling system

Solar and electric water heating system

Customize Solution:

If you are not sure about the parameters of thermostatic mixing valve, our engineering team will assist you with your selection or customize according to these details as follow:

Mixing water temperature range

Pressure and loss of pressure

Performance standard

Custom material and other parts

Dimension:

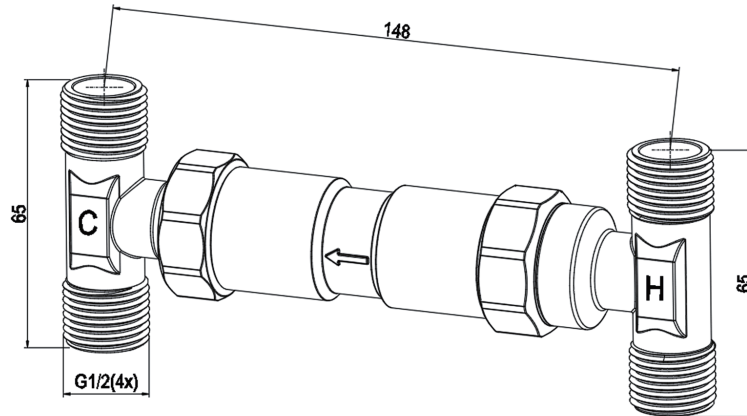

Installation Instructions:

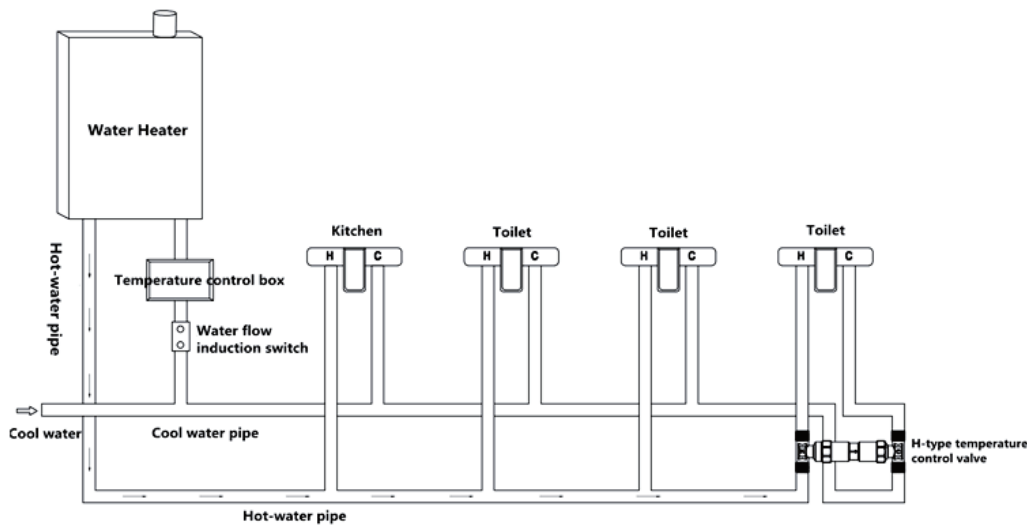

As shown in Fig, for the home water supply system installed with the intelligent temperature control valve of H-type water return system, in order to effectuate the use of hot water in the remotest main washroom, the user should turn on the faucet for 2-6 seconds and then turn it off, so that the water flow switch could sense the flow state of water in the pipeline, transform the flow state into an starting signal, and transmit the signal to the temperature control cycle control box, which will start the circulating pump. However, what is different from the existing ordinary home hot water circulating system is that when the temperature of the residual water in the hot water pipe in the remote main washroom is lower than the opening temperature of the valve, the valve opens, and the residual low-temperature water in the hot water pipe will be pumped back through the intelligent temperature control valve of H-type water return system, and the main cold water pipe connected with it, to the water heater to be reheated. Meanwhile, the hot water in the water heater also flows timely to the remotest main washroom. When the hot water flows through the intelligent temperature control valve of H-type water return system, as the temperature of hot water is higher than the closing temperature of the valve of H-type water return system, so the valve is closed at the moment and the hot water flows directly into the hot water pipe in the remotest main washroom, enabling the user to enjoy warm or hot water in time.