

## 930005NT Dynamic Flow Balancing Valve

### Description:

With modern heating and cooling systems, consumers are paying more and more attention to comfort, energy saving and consumption reduction.

To achieve these two points, it is necessary to meet the requirements of each end flow of the system within the design flow range. One problem is to ensure that when the flow at each end of the heating and cooling system fluctuates within a certain pressure difference range, or when the system is under partial load operation, the flow at each end is always within the design flow range, thereby effectively ensuring user comfort. At the same time, waste of energy is avoided.

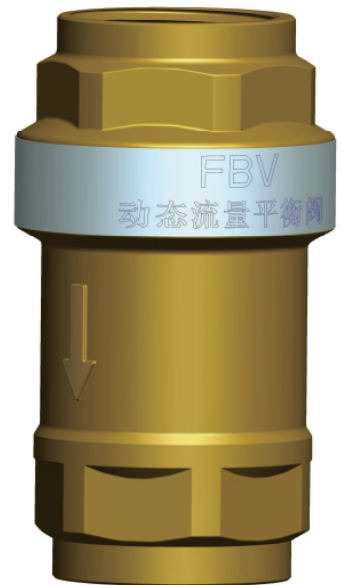

### Technical parameter:

Valve Body Material: Hpb59-1

Seal Material: high toughness plastic

Seal Material: EPDM

Medium: water

Max working pressure: 1.0Mpa

Connection: DN20(G3/4FXF)

Working Water temperature: 0°C ~90°C

Differential Pressure Range: 50-500Kpa

Flowing: 25±5L/min

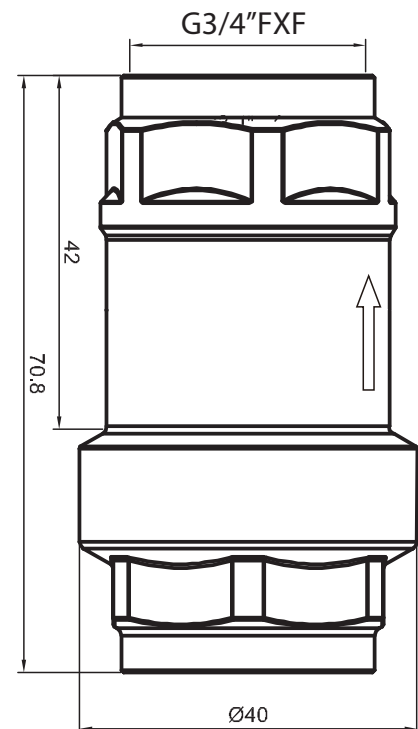

### Application:

District Heating System, air handling unit, fan coil, radiator and other terminal equipment and so on.

## Working Principle:

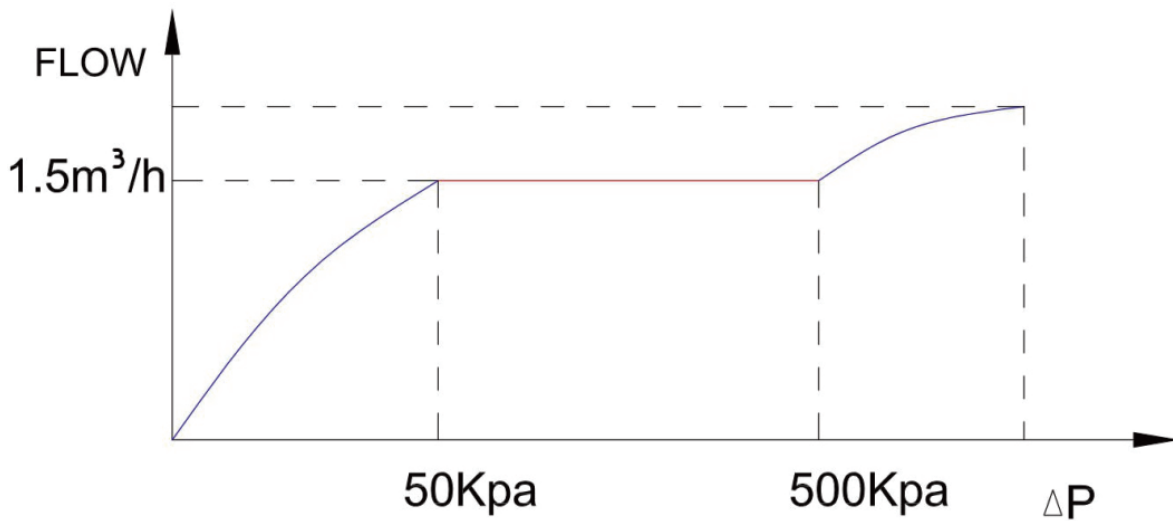

## Installation Attention:

When the pressure difference between the front and rear ends of the valve is less than the product design minimum pressure difference, the piston in the valve core does not control the gap of the water outlet, and the water flow rate at this time increases as the pressure difference increases;

When the pressure difference between the front and rear ends of the valve is greater than or equal to the product design pressure difference, the piston in the valve core automatically adjusts the gap of the variable diameter in the valve core under the action of the spring, so that the flow of the variable diameter portion gradually decreases, but is fixed. The flow of the path part gradually increases, and the sum of the two flows remains constant;

When the pressure difference between the front and rear ends of the valve is greater than the product design maximum pressure difference, the piston in the valve core closes the variable diameter water outlet under the action of water pressure. At this time, the water flow is discharged from the fixed diameter water outlet, and the flow rate increases with the pressure difference. Large and increased

## Installation:

